

AUTOMATIC IN-CAN PRODUCTION LINE

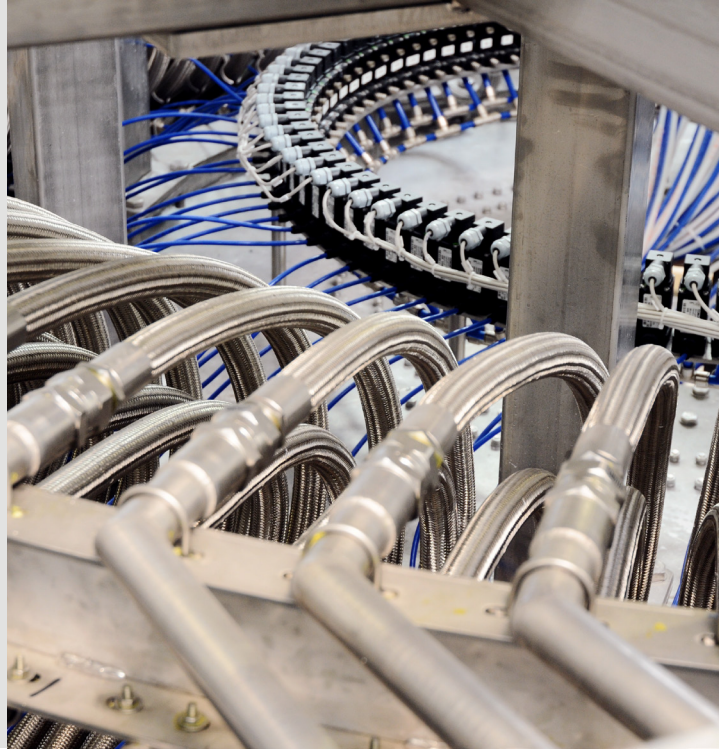

**Enhance your
productivity with
the power of fully
automated solutions**







Our complete range of In-Can automated systems for high-performance and just-in-time production empowers a single operator to handle large numbers of customer orders with ease.

COROB's fully automatic In-Can production lines are the perfect solution for companies that require flexibility to meet extensive and diverse daily demand for tinted paint or products.

By integrating a COROB In-Can production system in strategic distribution centers, serving remote or demanding markets becomes a breeze.

You can reduce warehouse space, inventory, and working capital while increasing profitability by shortening delivery times.

The COROB solution is fully customizable to meet any budget or space requirement, allowing you to minimize costs, maximize production, and increase factory efficiencies with the automatic production line.

-  **STREAMLINED AUTOMATION**
The fully automated production process reduces labor requirements and eliminates the need for skilled operators
-  **DESIGNED AROUND YOU**
Tailored solutions to meet your specific performance, productivity, and space requirements
-  **FLEXIBLE AND CONVENIENT**
Reduce inventory requirements with fast just-in-time production for empty or pre-filled cans
-  **EFFICIENT PRODUCTION**
Experience seamless production flow, from order management to palletizing of finished products

ABOUT US

COROB is a global leader with a long and successful history in developing, manufacturing and delivering high-tech dispensing and mixing solutions for the widest range of tinting applications. Our offering is supported by a global service network making COROB a total solution provider.



AUTOMATIC IN-CAN PRODUCTION LINE

Enhance your productivity with the power of fully automated solutions

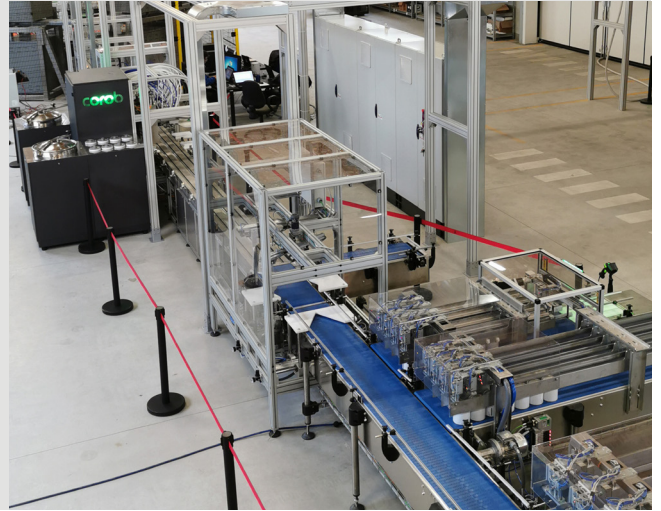

TAKING CONTROL OF THE BOTTOM-LINE

- High-volume tinted product generation in a small footprint.
- Just-in-time availability of any product and color in any pack size.
- Reduction of net working capital by minimizing the level of stocked goods.
- Consistent delivery of required products on time and in full, increasing customer satisfaction.
- Quick switching from one order to another with no setup time required.
- Always profitable, without the need for minimum batch quantities.

MAIN BUSINESS APPLICATIONS

Consult with COROB specialists and selected partners to define the best In-Can automation system for your business needs. We offer infinite possibilities, solutions, and configurations delivering consistent, high-quality results in a wide range of business applications:

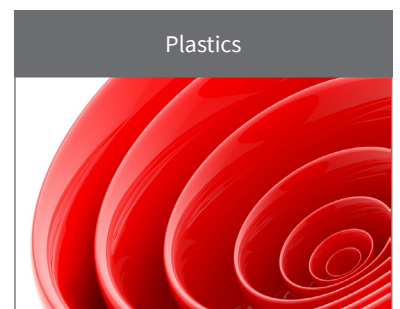
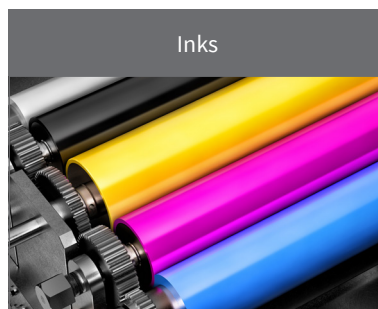
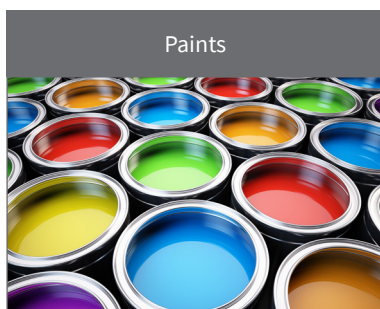

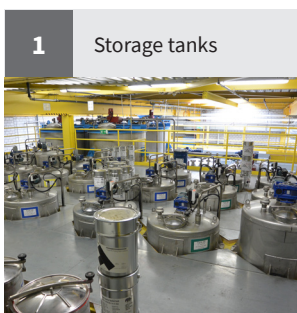
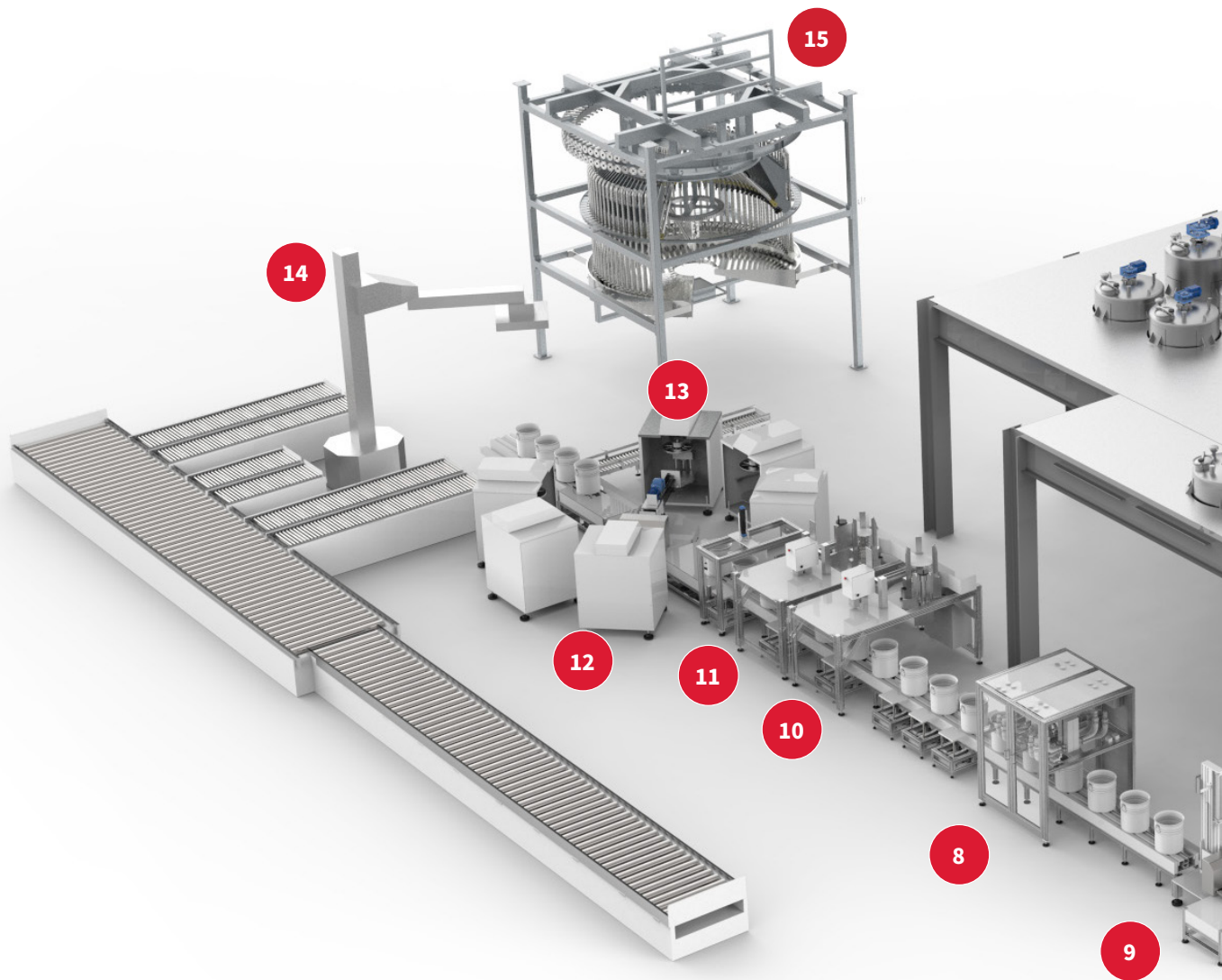

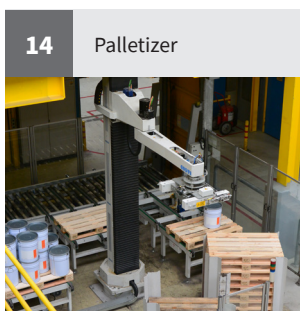
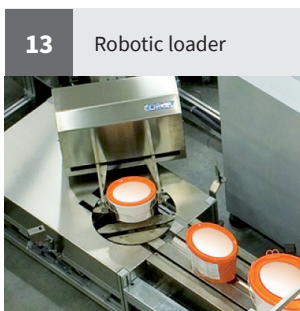
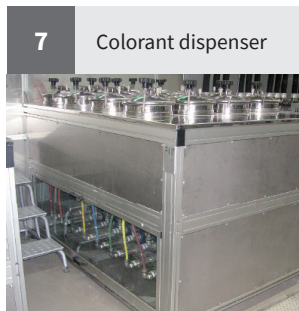
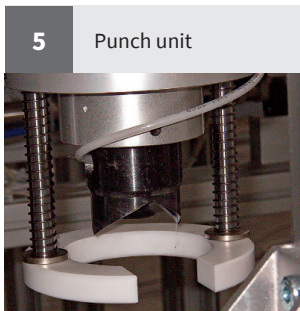
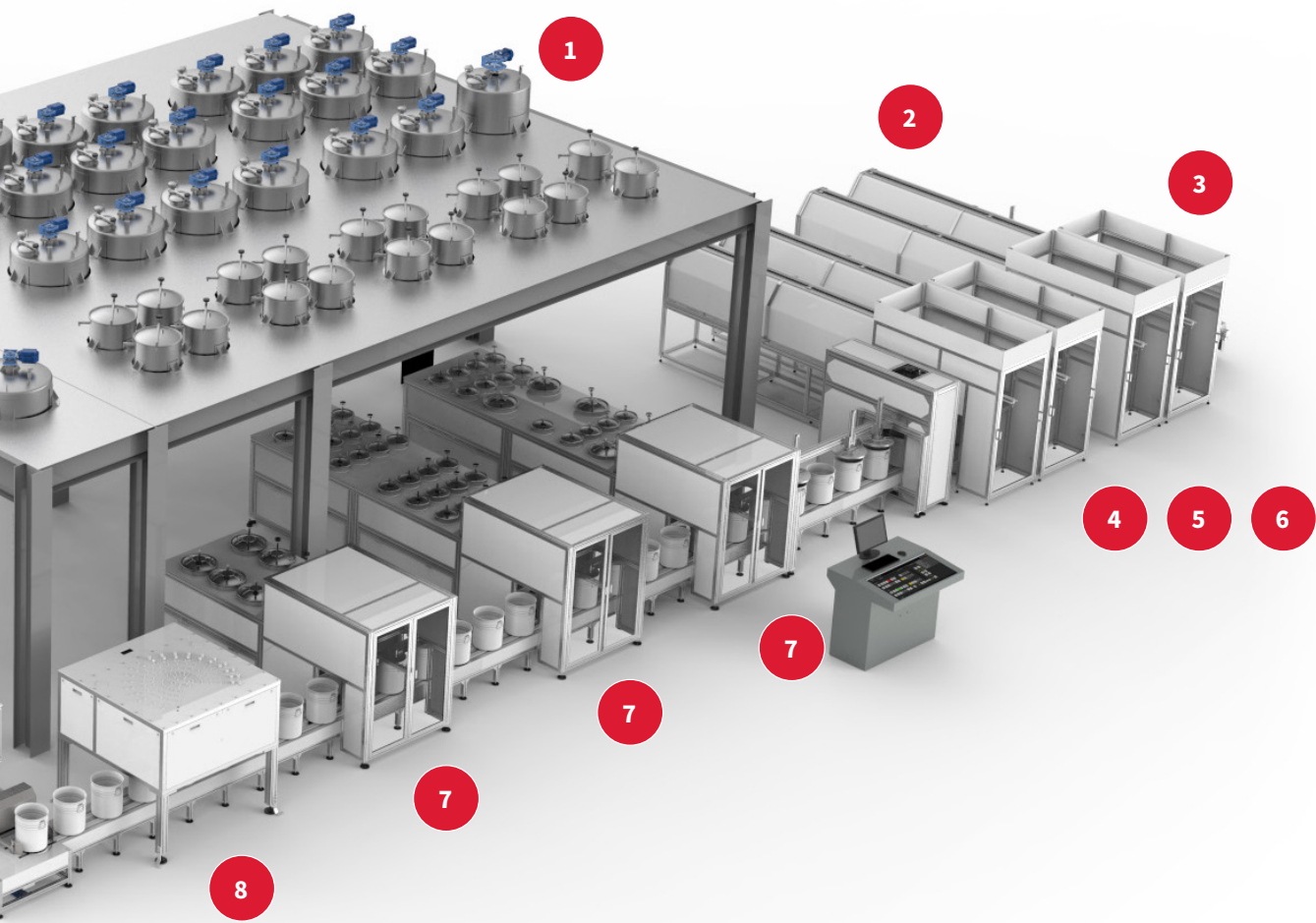

PRODUCT LINE-UP BY COROB

COROB offers a wide variety of customizable systems and products for factory automation:

AUTOMATIC PRODUCTION LINES	In-Can fully automatic production lines
MODULA	MODULA TDF (Tinting During Filling)
	MODULA V (Volumetric tinting)
	MODULA VG (Volumetric tinting & Gravimetric filling)
MIXING SYSTEMS	MIXING STATION MS-RG (Robotics)
	MIXING STATION MS-LG (In-Line)

COROB CONSULTANCY AT YOUR SERVICE

Investing in a COROB In-Can System is a crucial step that requires support and expertise from all parties involved. At COROB, customers come first, and the system is customized to meet individual needs. We will be with you every step of the way, from the beginning of the project to its conclusion. Consulting with our specialized staff and selected partners is essential to finding the best solution for your needs. This process is a true partnership between COROB and our customers.



AUTOMATIC IN-CAN PRODUCTION LINE



BUILDING YOUR IN-CAN SYSTEM

The range of businesses that can benefit from adopting an In-Can System is extensive, and so is the variety of parts that make up the system.

Each COROB system is tailored to the customer's specific needs and fine-tuned to strike the best balance between cost and required performance.

Myriad tools and devices can be combined to create the optimal system.

Please contact a specialized COROB consultant to explore available options and solutions.

